

MODEL
Freewing

A-4E/F Skyhawk

FREEWING 1/9 SCALE EDF JET

USER MANUAL

WINGSPAN:940MM

LENGTH:1430MM

EMPTY WEIGHT:2200G

(W/O BATTERY)

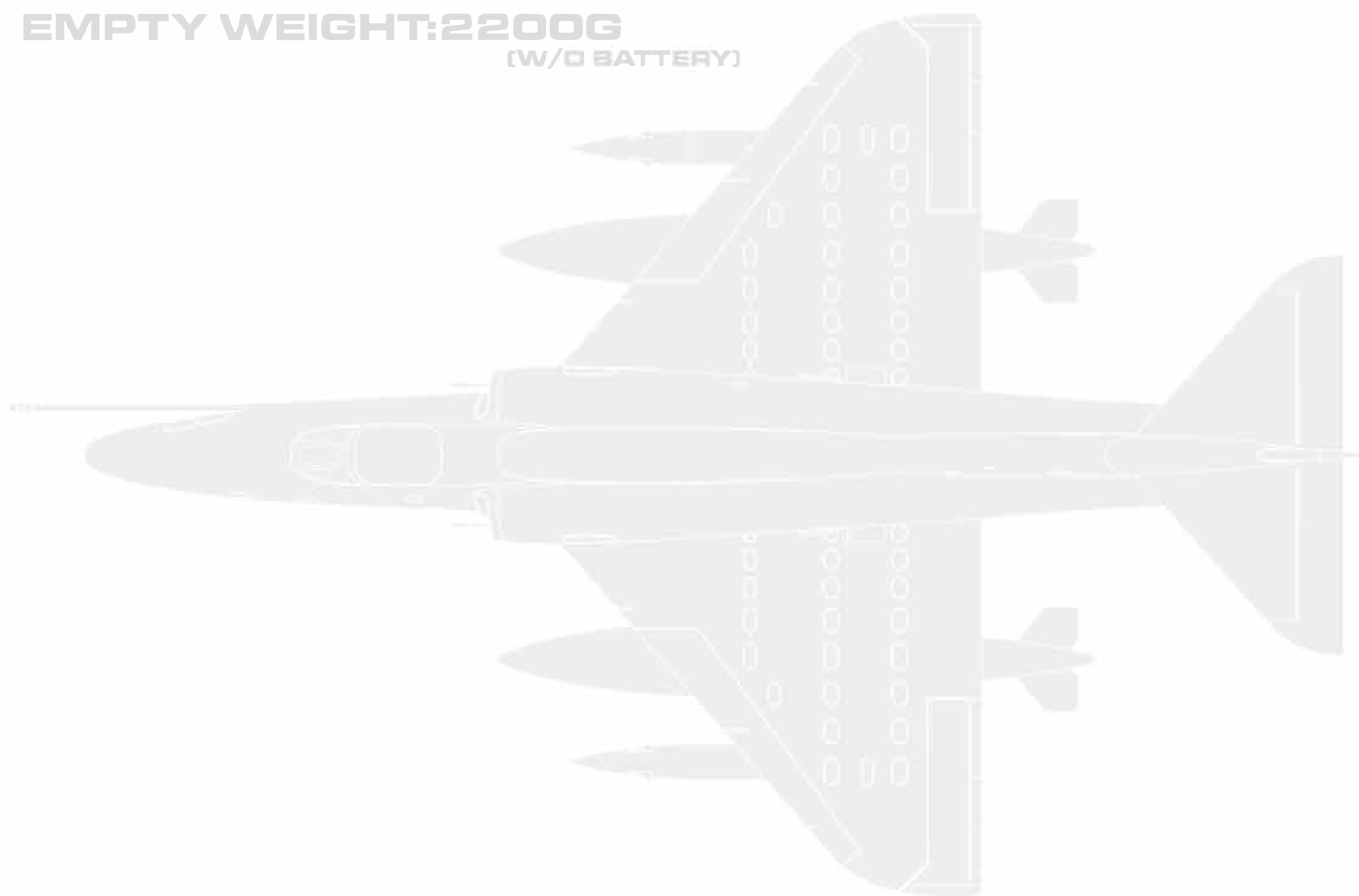

www.sz-freewing.com

MADE IN CHINA

EN

1~11

中

12~22

The A-4 Skyhawk commands a beloved place in aviation history. Designed by the innovative Ed Heinemann for Douglas Aircraft in the 1950s, the A-4 was optimized as a multi-role aircraft that used its low weight, high maneuverability, and straightforward reliability to lethal advantage. This aircraft's nearly 70 year history of distinguished service and its continued operation by certain countries to this day is testament to the timelessness of "Heinemann's Hotrod."

To honor this famed aircraft, Freewing and Motion RC proudly offer the Freewing 80mm A-4E/F Skyhawk, the first large foam electric PNP mass production A-4 in the world!

This flying model is powered by a 3530-1850kv brushless outrunner motor and 12 blade EDF ducted fan, achieving a top speed of 106mph/170kph using the recommended 6s 4000mAh-5200mAh battery.

The Freewing 80mm A-4E/F Skyhawk features all new fold-and-twist retracts, with durable aluminum trailing link struts for confident operation on rough grass runways. Removable wings and flexible wing wire harnesses make transportation very convenient. Beyond the overall scale profile fidelity, other scale details include plastic split flaps, and detachable fuel tanks, AGM-12 missiles, and refueling probe.

Adding to the model's versatility, the later version avionics "hump" is also included! Attach this magnetic "hump" onto the fuselage's top spine to change between the -E and -F variations of the Skyhawk. Two decal sets are also included, depicting a US Navy A-4 from VA-22 and a US Marines A-4 from VMA-311. Fly these with pride, or personalize with another livery of your choosing!

⚠ NOTE: This is not a toy. Not for children under 14 years. Young people under the age of 14 should only be permitted to operate this model under the instruction and supervision of an adult. Please keep these instructions for further reference after completing model assembly.

Note:

1. This is not a toy! Operators should have some basic experience. Beginners should operate only under the guidance of a professional instructor.
2. Before beginning assembly, please read through the instructions and carefully follow them throughout the build.
3. Freewing and it's vendors will not be held responsible for any losses due to improper assembly and operation.
4. Model airplane operators must be at least 14 years of age.
5. This airplane is made of EPO foam material, covered with surface spray paint. Don't use chemicals to clean as it may cause damage.
6. You should avoid flying in areas such as public places, areas with high voltage power lines, nearby highways, airports or in other areas where laws and regulations clearly prohibit flight.
7. Do not fly in bad weather conditions, including thunderstorms, snow, etc...
8. Lipo batteries should be properly stored in a fire proof container and be kept at a minimum of 2M distance away from flammable or explosive materials.
9. Damaged or scrap batteries must be properly discharged before disposal or recycling to avoid spontaneous combustion and fire.
10. At the Flying Field, properly dispose of any waste you have created, don't leave or burn your waste.. Ensure that your throttle is in the low position and that your radio is turned on before connecting the Lipo battery.

Catalog

Introduction.....	1	Magnetic Nose Cone & Avionics Package Installation...	5
Basic Production Information.....	2	Scale Accessories Installation.....	6
Package List.....	2	Pushrod Instructions.....	6
Fuselage assembly.....	3	Control Board connection diagram.....	7
Horizontal/Vertical Stabilizer Installation.....	3	Battery size and Installation.....	8
Main Wing Installation.....	4	Center of Gravity.....	8
Missile and Drop Tank Installation	5	Introduction to Servos.....	9
		Motor parameters.....	9
		Flight Surface Directional control test.....	10
		Dual Rates and Flight Precautions.....	11

Basic Product information

EN

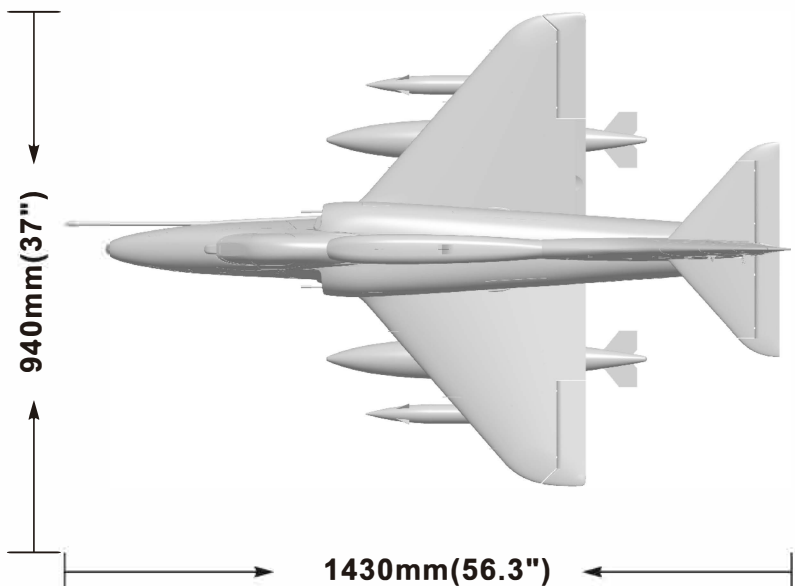

940mm(37")

1430mm(56.3")

Standard version

Wing loading: 116g/dm²
 Wing area: 24 dm²
 Motor: 3530-1850KV
 brushless outrunner motor
 Ducted fan: 80mm 12-blade fan
 ESC: 100A brushless
 Servo: 17g digital metal gear servo (1pc)
 9g digital metal gear servo (6pcs)
 Flight speed : 170KPH/110MPH
 Empty Weight: 2200g (without battery)
 Thrust: 3200g (Uninstalled Bench Test)

Other features

Material : EPO
 Aileron: Yes
 Split Flaps: Yes
 Elevator: Yes
 Rudder: Yes
 Landing gear: Retractable, Suspension
 Scale Pilot figure
 Battery : 6S 4000~5200mAh (1pc)

Note: The parameters stated here are derived from test results using our accessories. If you use other accessories, the test results will differ. We cannot provide technical support if you have a problem when using other accessories.

Package list

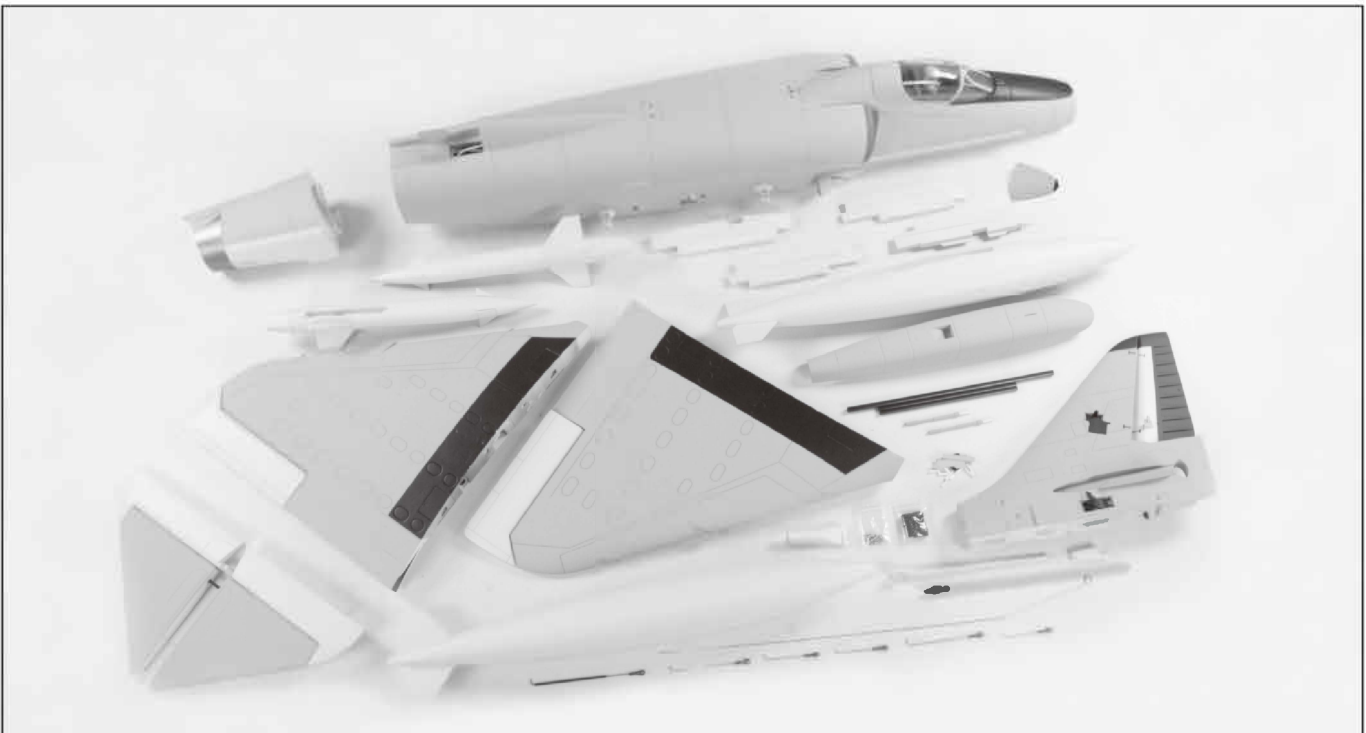

Different equipment include different spareparts. Please refer to the following contents to check your sparepart list.

No.	Name	PNP	ARF Plus	Airframe	No.	Name	PNP	ARF Plus	Airframe
1	Fuselage	Pre-installed all electronic parts	Pre-installed servo	No electronic equipment	1	Scale accessories	✓	✓	✓
2	Main wing	Pre-installed all electronic parts	Pre-installed servo	No electronic equipment	2	Linkage Set	✓	✓	✓
3	Horizontal tail	✓	✓	✓	3	Carbon tube & Cannon barrels	✓	✓	✓
4	Vertical tail	Pre-installed all electronic parts	Pre-installed servo	No electronic equipment	4	Glue & Non-slip mat	✓	✓	✓
5	Drop tank & missiles	✓	✓	✓	5	Manual & Decals	✓	✓	✓
6	Magnetic Nose cone & drop tanks	✓	✓	✓	6	Screws	✓	✓	✓

Steel wire use instruction

To minimize servo connections, the Elevator and Rudder servos' wires each reach from the servo itself directly to the receiver. A rigid steel wire hook is included in the box to allow you to pull the servo wires through the model's internal fuselage.



Fuselage Assembly

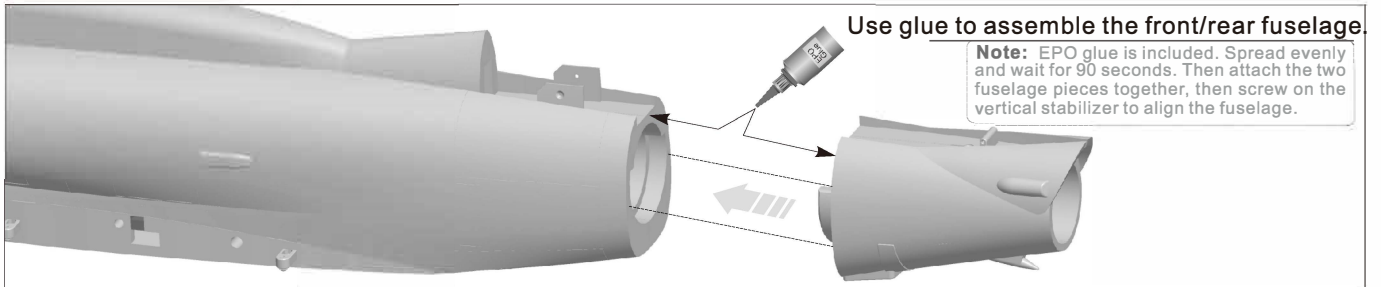

Horizontal stabilizer / Vertical stabilizer Assembly

Step 1

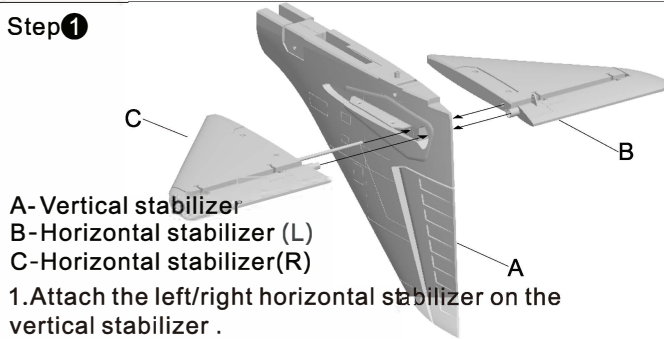

Step 2

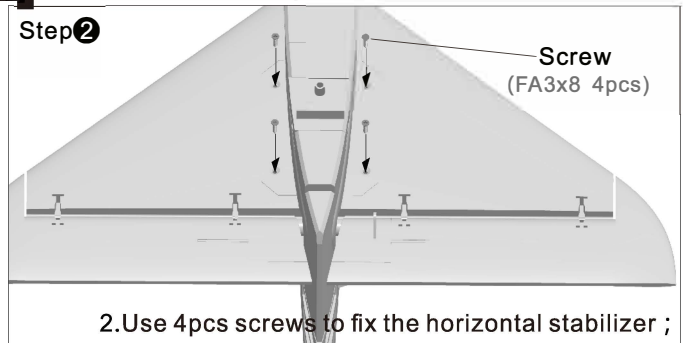

Referring to the photo:

3. Use traction wire to pull the elevator/rudder servo cables to the battery compartment
4. Place the vertical stabilizer to the tail slot on the fuselage
5. Use the 4 screws to anchor the vertical stabilizer.

- A- Vertical stabilizer
- B- Servo cable
- C- Screws (FA3x8 4pcs)

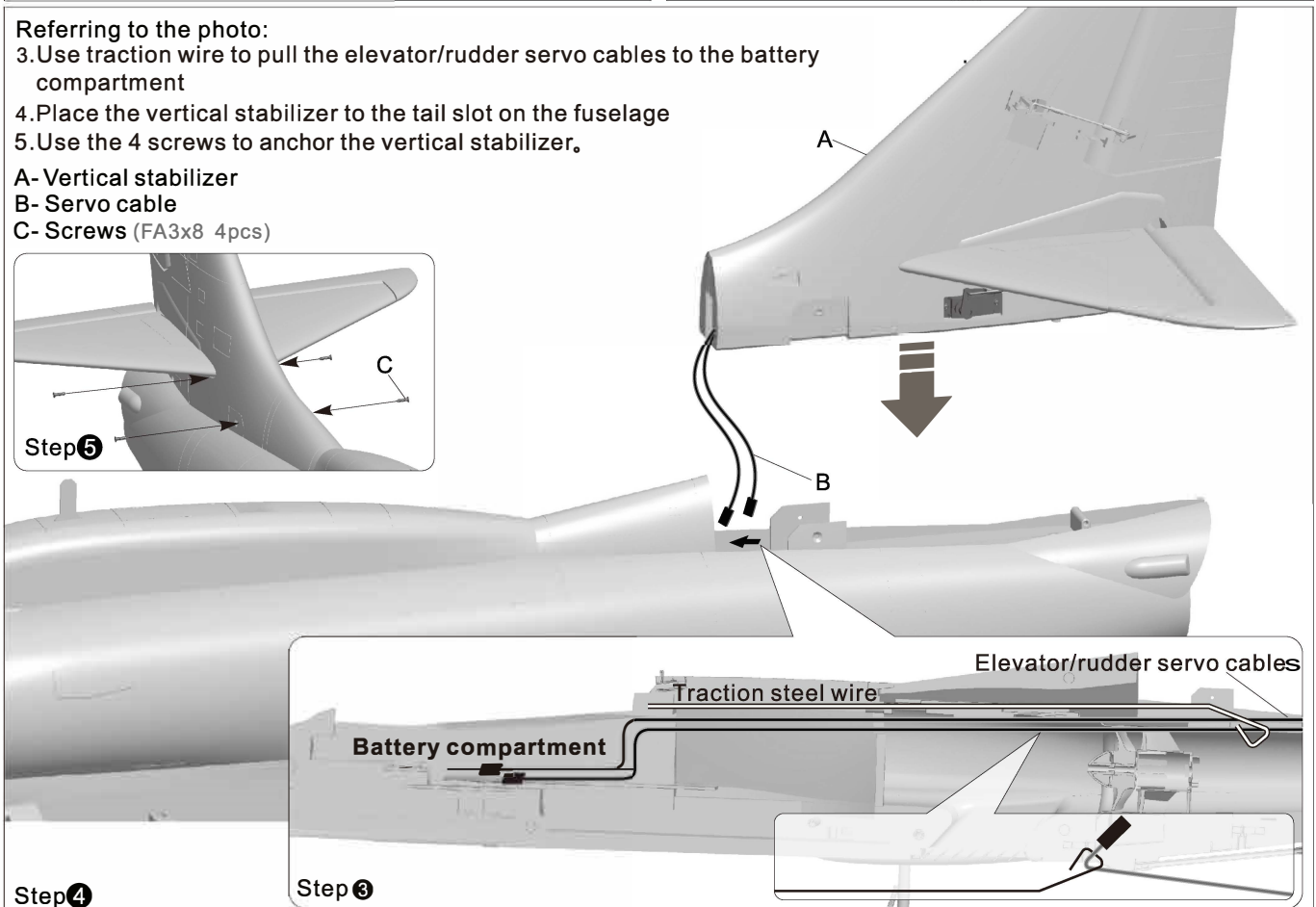
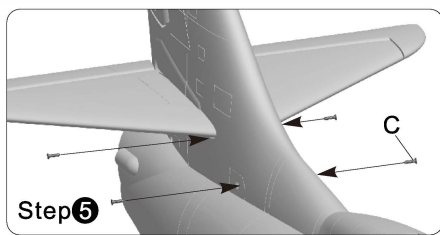

Main wing Installation

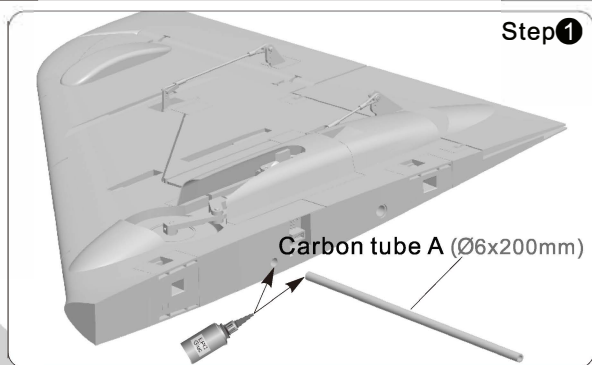
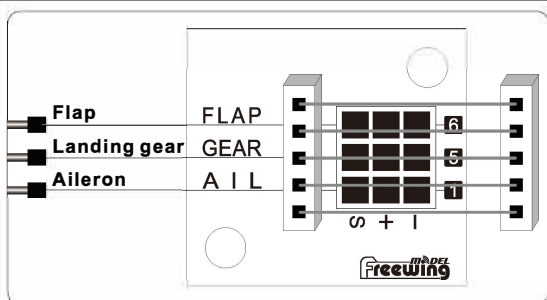

Step 1

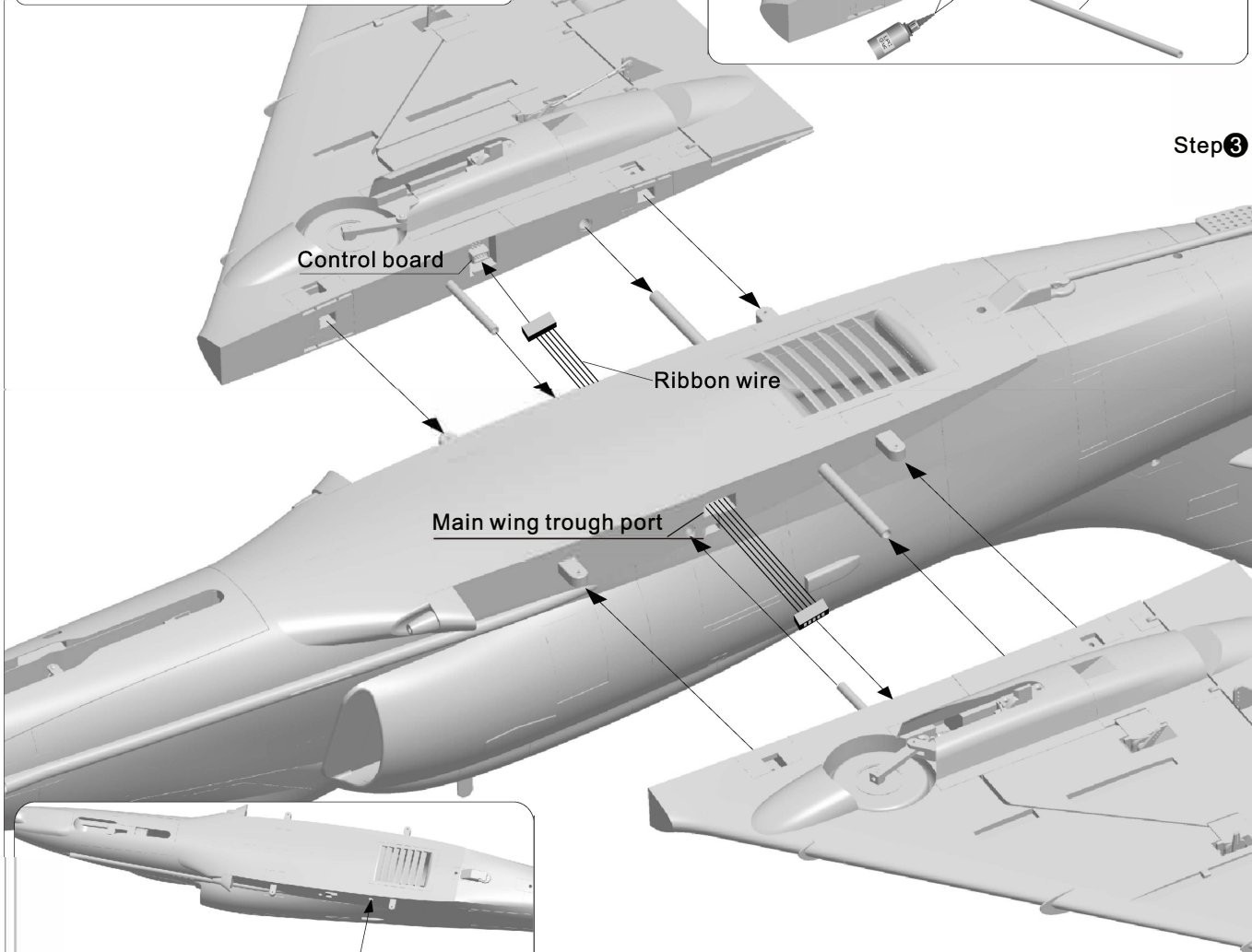

Step 3

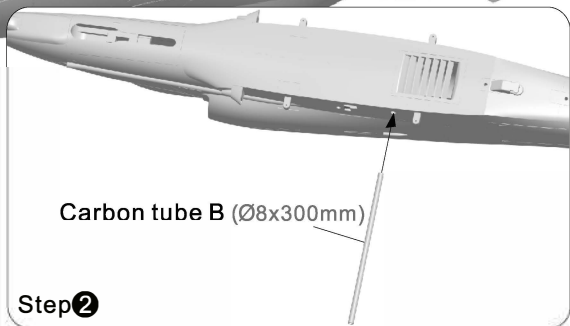

Step 2

Referring to the Photo:

1. Apply glue to one end of carbon tube A, and insert the glued end into the main wing, ensuring both sides of the exposed rod are equal in length.
2. Insert carbon tube B through the fuselage, do not use glue if you wish to be able to remove the wings.
3. Insert the ribbon wire to the control board, then install the left/right main wing to the fuselage.
4. Use 4 screws to fix the main wing.

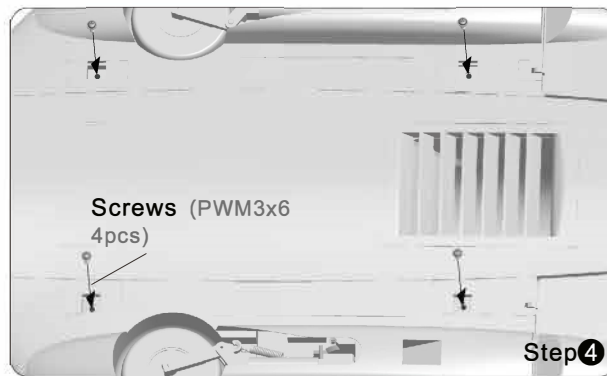

Step 4

Missiles & Drop tank Installation

Install the missiles, pylons, and drop tanks referring to these photos.

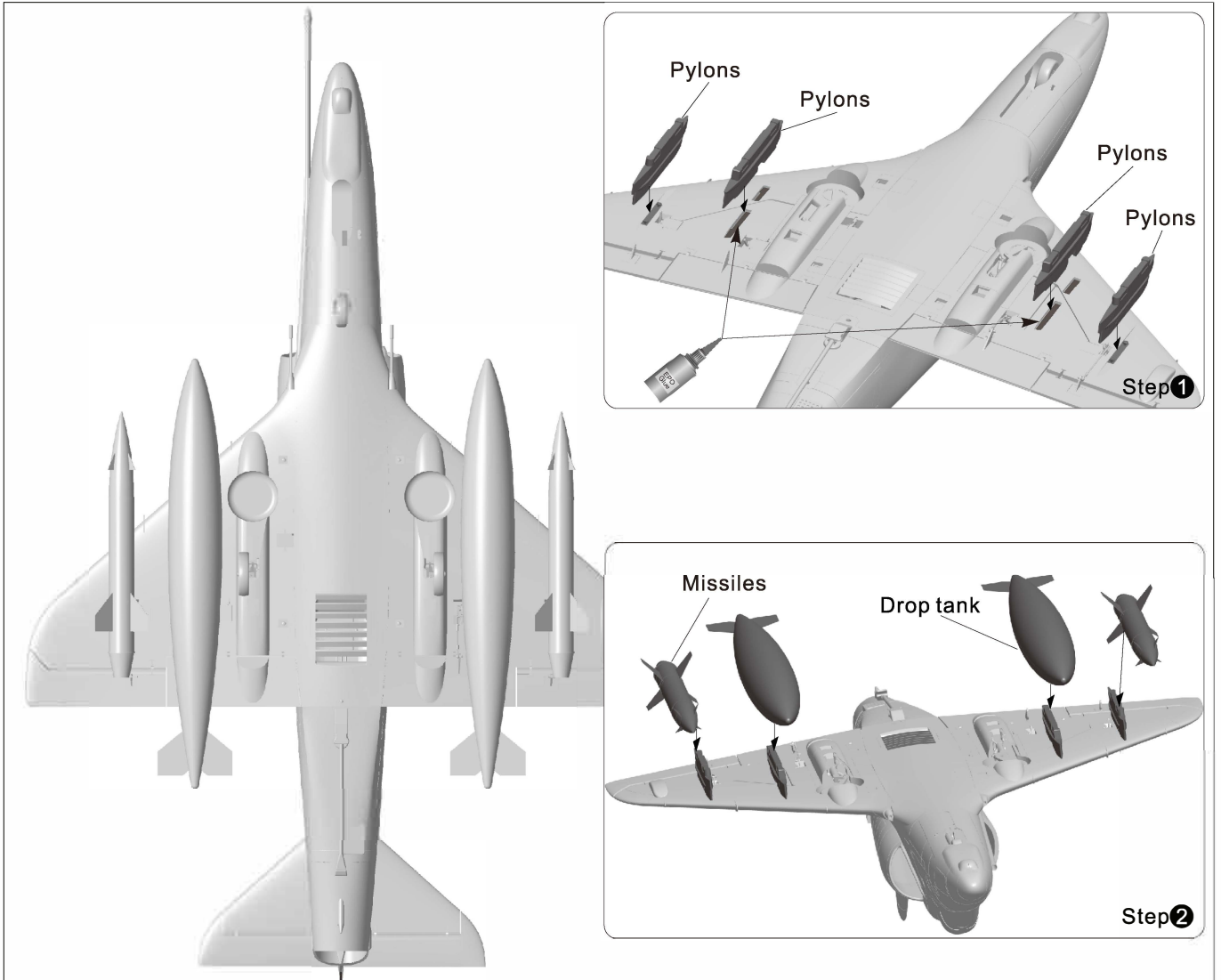

Magnetic nose cone and avionics package Installation

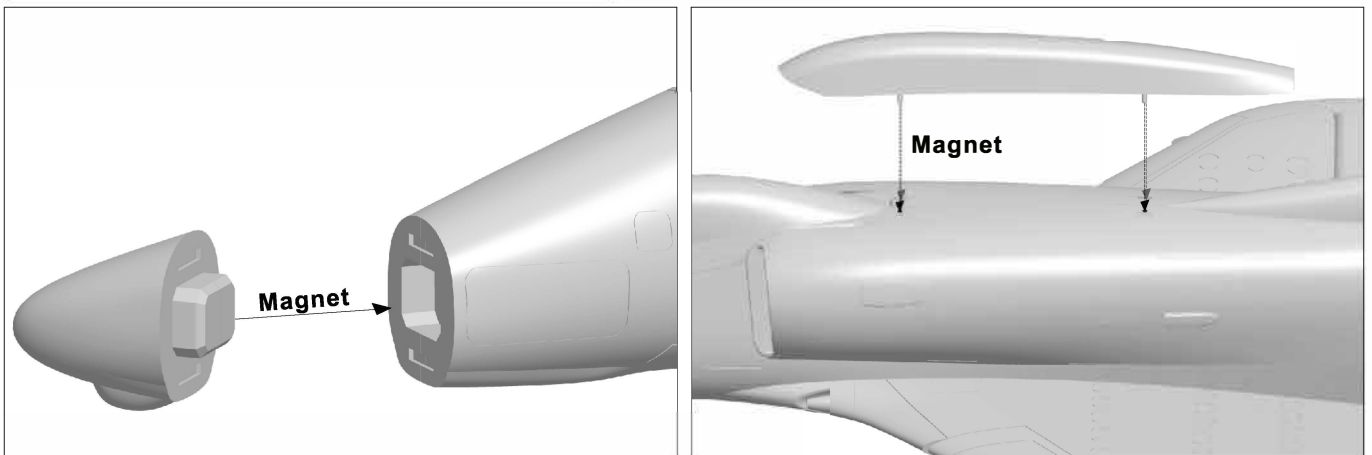

Scale Accessories Installation

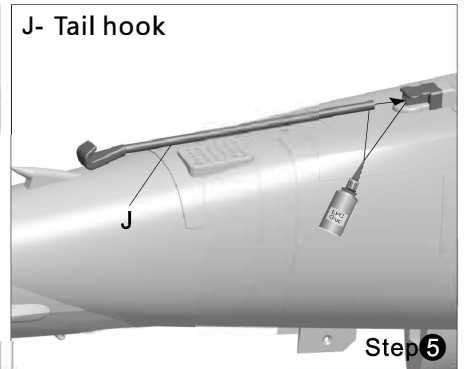
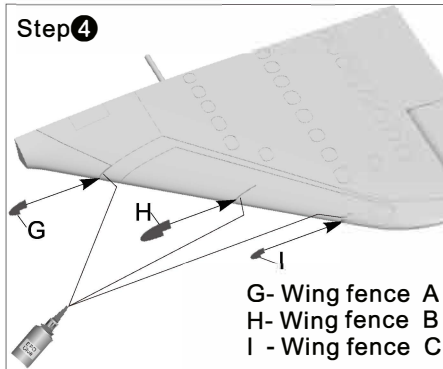
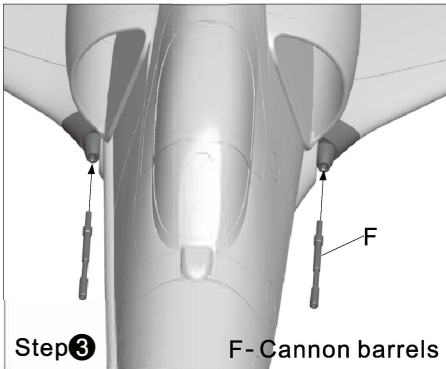
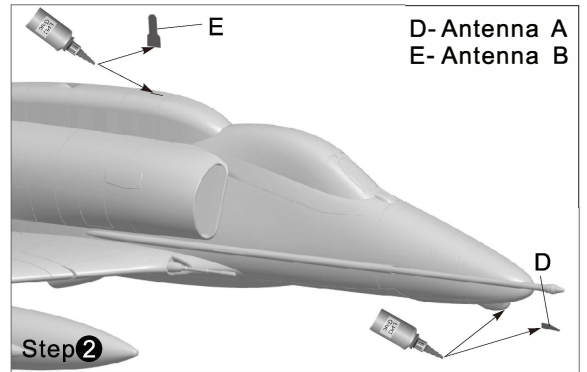
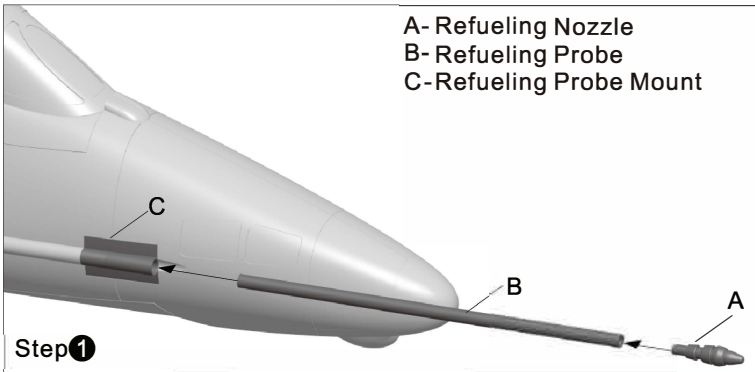

Pushrod Instructions

Aileron pushrod size



Aileron pushrod mounting hole



Flap pushrod size

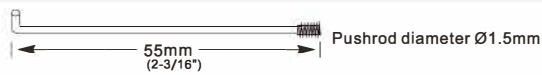

Flap pushrod mounting hole



Elevator pushrod size



Elevator pushrod mounting hole



Rudder pushrod size



Rudder pushrod mounting hole



Control board connection diagram

The A-4 uses a convenient flexible ribbon wire harness to consolidate wiring. Connect as shown in the photo.

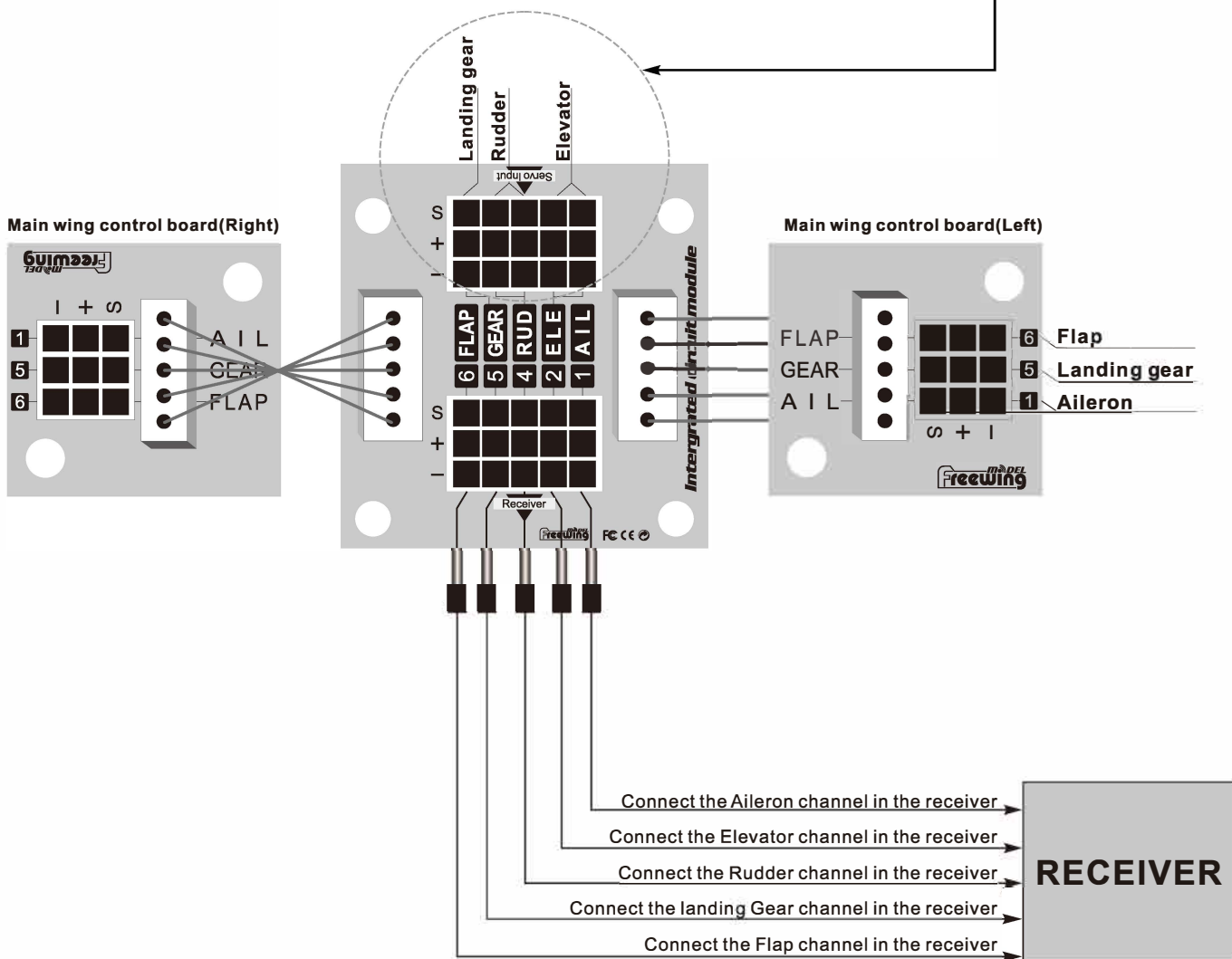
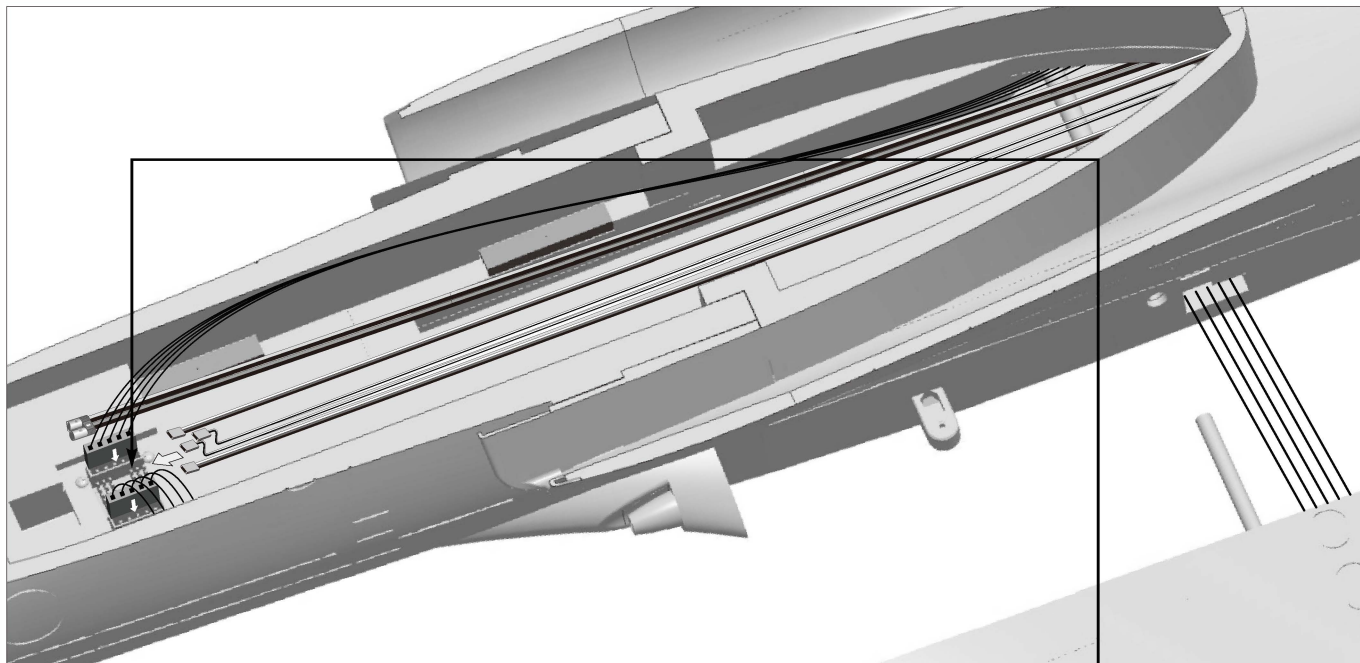

Battery Size and Installation

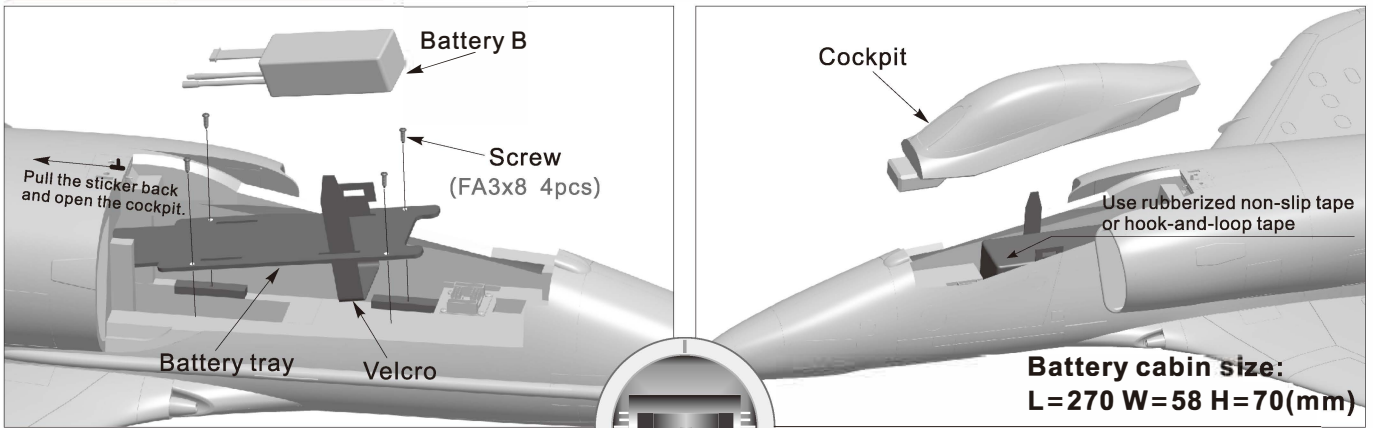

Before connecting the battery to the ESC, please switch on your transmitter and make sure the throttle stick is in the lowest position.

We recommend the following LiPo battery:
6S 22.2V 4000mAh ~ 6S 22.2V 5200mAh
 (Discharge rate of C ≥ 35C)

Center of Gravity

The correct center of gravity will determine the success of the initial flights, please refer to the following CG diagram to adjust your plane's center of gravity.

- You can move the battery forward or backward to adjust the center of gravity.
- If you can not attain the proper CG by moving the battery, you can also use some other suitable material such as sticky back weight to help make sure that CG is in the correct position.
- After the initial flights are complete, you can adjust the CG to meet your individual preference.

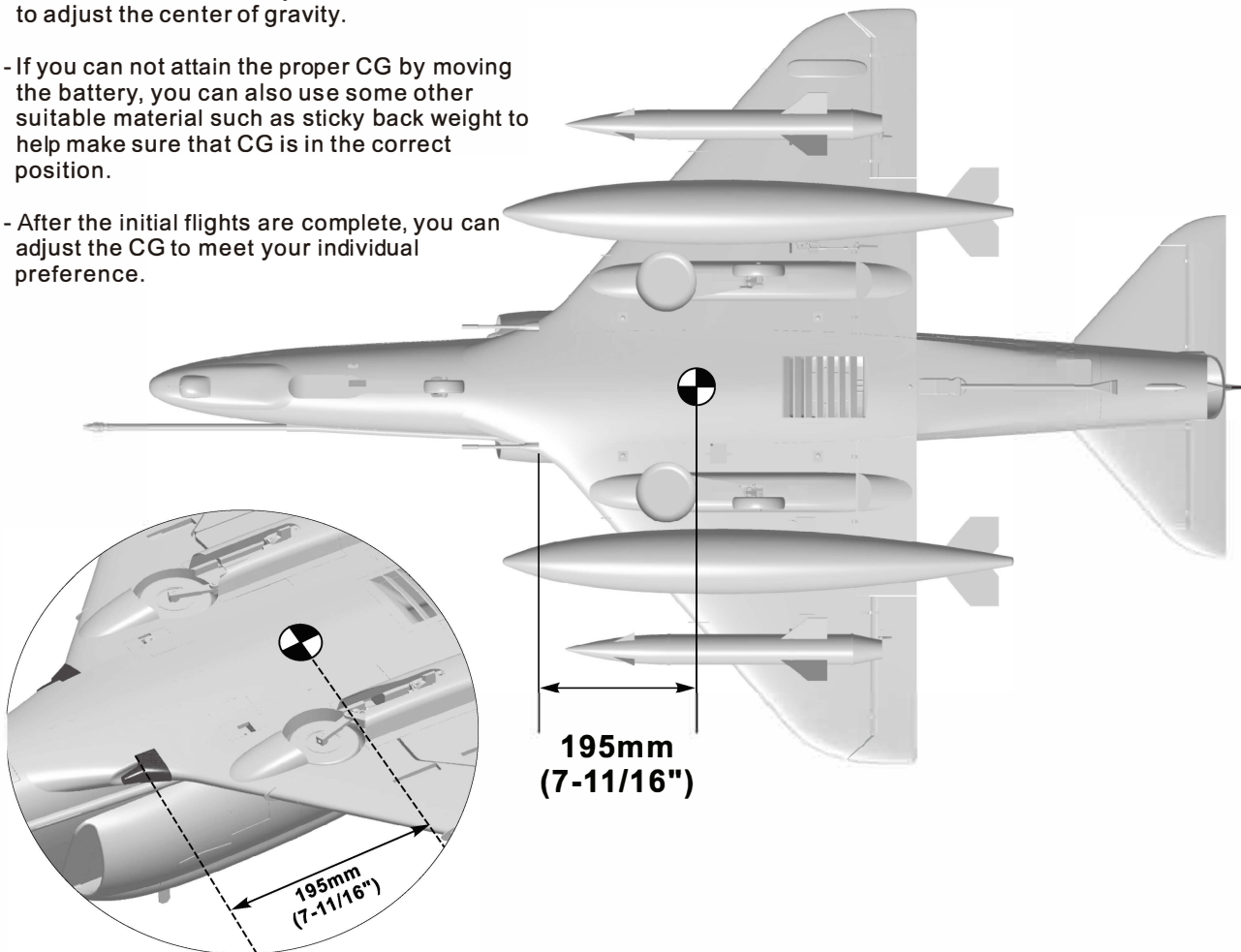

Servo Introduction

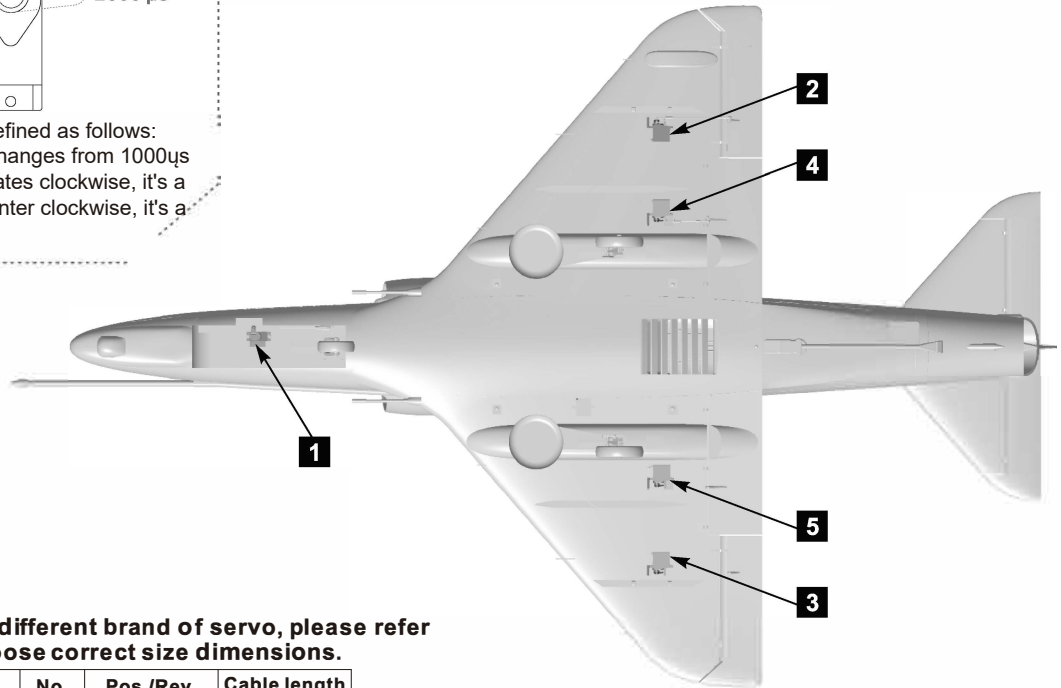
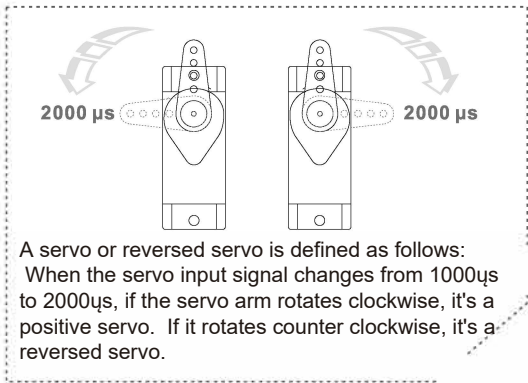

If you need to purchase a different brand of servo, please refer to the following list to choose correct size dimensions.

Position	Model	No.	Pos./Rev.	Cable length
Nose gear steering servo	9g Digital-MG	1	Positive	100mm
Aileron(L)	9g Digital-MG	2	Positive	250mm
Aileron(R)	9g Digital-MG	3	Positive	250mm
Flap(L)	9g Digital-MG	4	Positive	250mm
Flap(R)	9g Digital-MG	5	Positive	250mm
Elevator	17g Digital-MG	6	Positive	950mm
Rudder	9g Digital-MG	7	Positive	1050mm

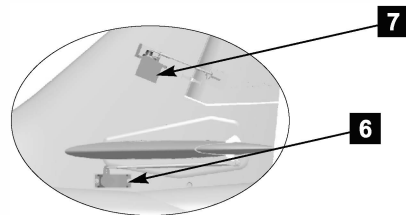

Motor Parameters

MO035304
3530-1850KV

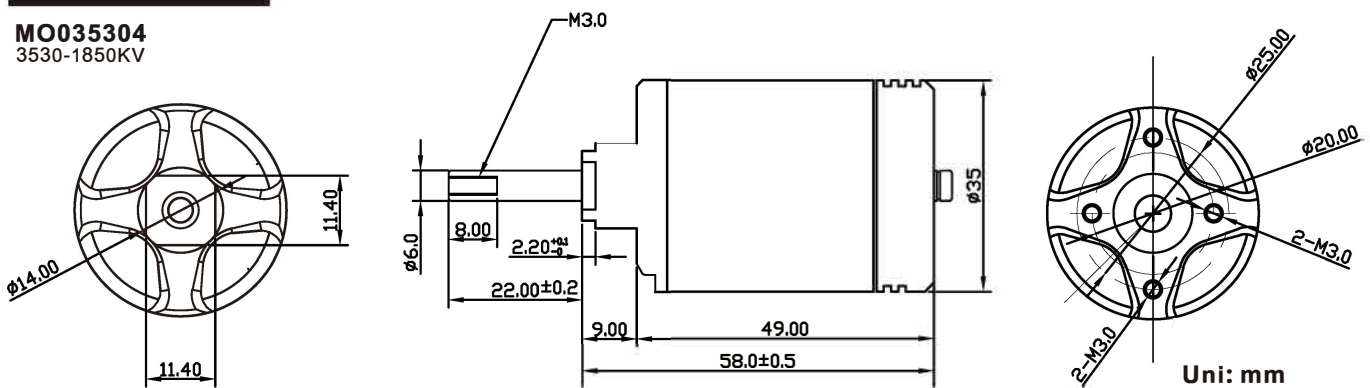

Item No.	Use motor	motor(KV)	Thrust(kg)	Current(A)	Use voltage (V)	Use ESC (A)	EDF Weight (g)	Max power (W)	Efficiency (g/w)
E7239	MO035304 3530-1850KV	1850	3200 (Bench)	90	22.2(6S)	100	318	2000	1.67

Control direction test

After the airplane assembly is complete, before first flight, power up your transmitter. Connect a fully charged battery to the ESC. Utilizing the radio, test and check that every control surface moves in the proper direction.

Aileron

Stick Left



Stick Right

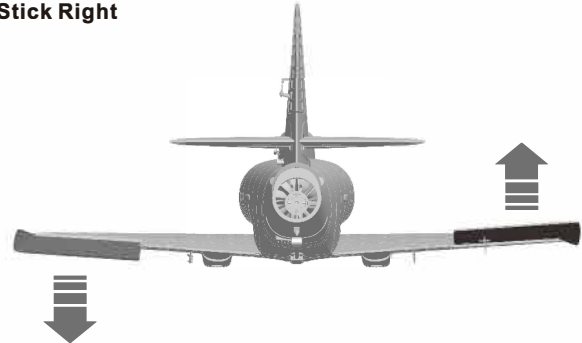

Elevator

Up Elevator

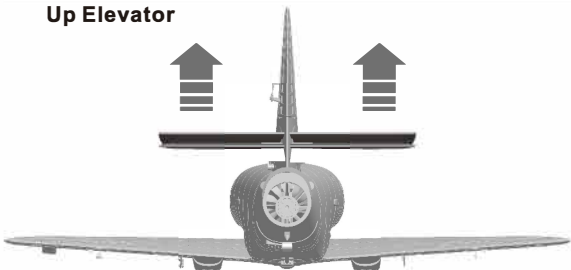

Down Elevator

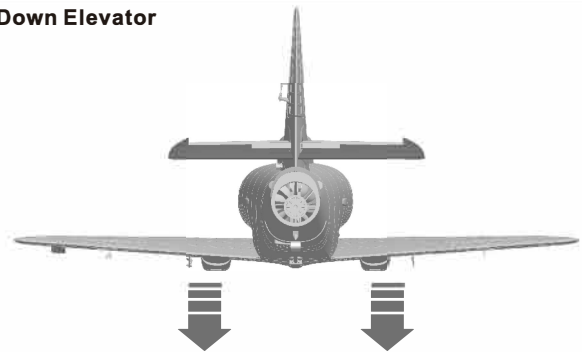

Rudder

Stick Left

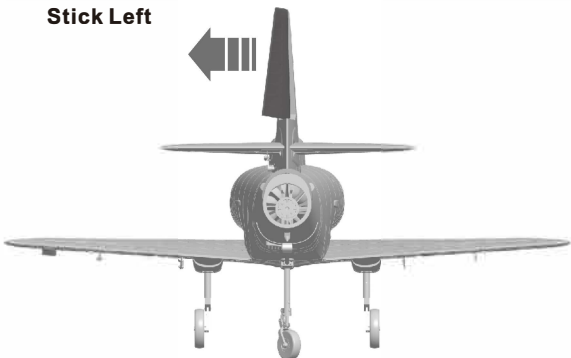

Stick Right

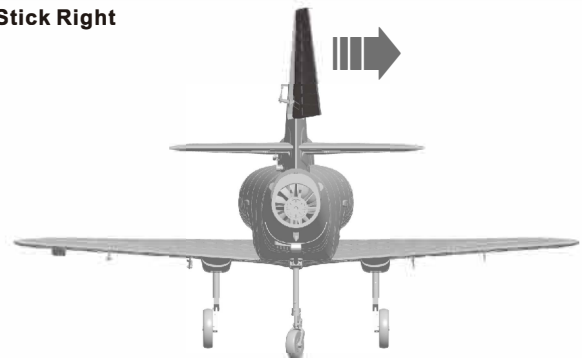

Flaps

Flaps down

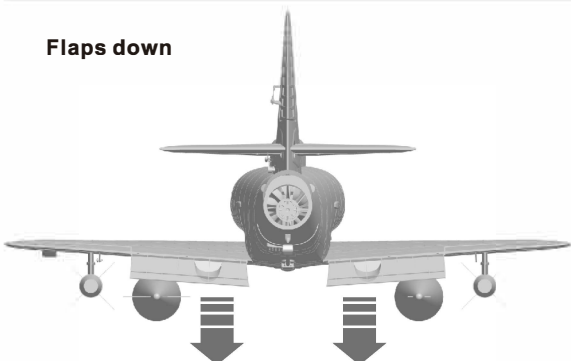

Note: Check to ensure that the controls are in the neutral position when no control input is used and that the flaps are evenly deflected. Adjust the clevis on the control rods if needed.

Dual rates

According to our test results, the following rates proved to be a good starting point. Low rates are good for initial flights or less experienced pilots. Adjust rates to suit you own style.

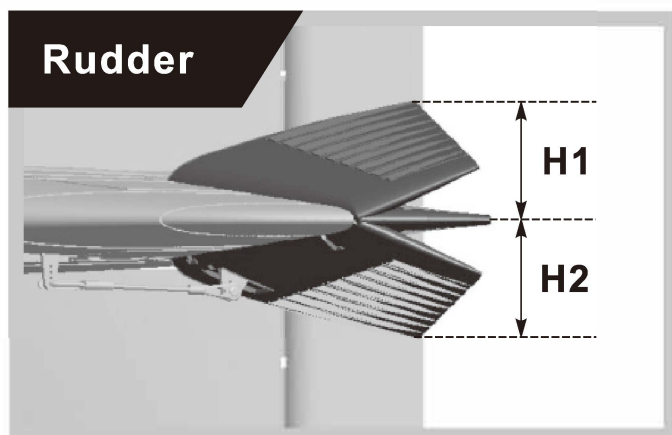
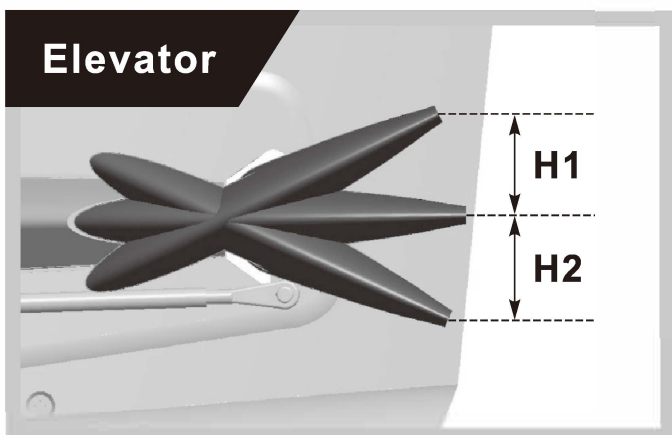
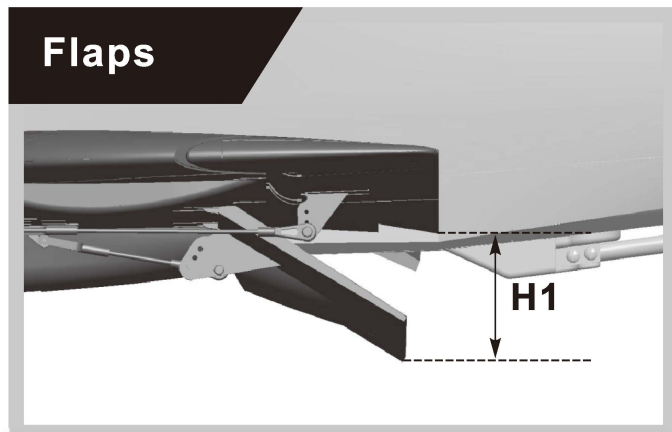
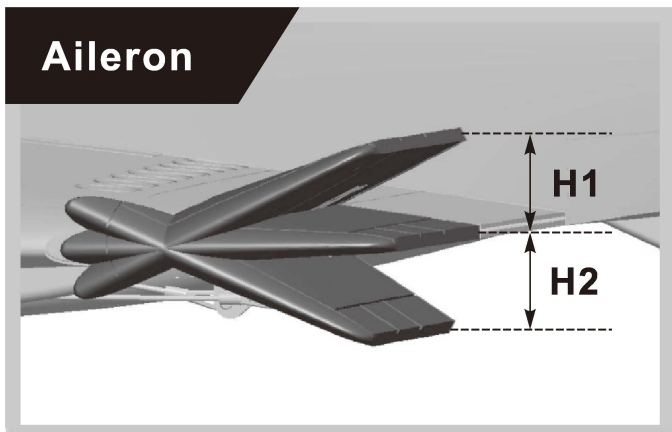

	Aileron(measured closest to the fuselage)	Elevator(measured closest to the fuselage)	Rudder(Measured from the bottom)	Flaps
Low Rate	H1/H2 18mm/18mm D/R Rate : 65%	H1/H2 21mm/21mm D/R Rate : 80%	H1/H2 24mm/24mm D/R Rate : 80%	H1 27mm
High Rate	H1/H2 24mm/24mm D/R Rate : 100%	H1/H2 25mm/25mm D/R Rate : 100%	H1/H2 30mm/30mm D/R Rate : 100%	H1 43mm

⚠ Flight Precaution:

- When the flaps are down, the nose will want to drop as well. To counter this, create a flap-to-Up-elevator mix in your radio. Set the mix parameter as follows:
 Flap rate: 27mm, mix the elevator rate: 2mm
 Flap rate: 43mm, mix the elevator rate: 3.5mm
- The weapons weight of this model makes the model tail heavy. When you fly with full weapons, please check the CG again.



Dongguan Freewing Electronic Technology Ltd
HK Freewing Model International Limited

Add.: Fei Yi Building, face to Labor Bureau, Fumin Middle Road, Dalang Town,
Dongguan City, Guangdong Province, China
Web: <http://www.sz-freewing.com>
Email: freewing@sz-freewing.com
Tel: 86-769-82669669 Fax: 86-769-82033233

东莞市飞翼电子科技有限公司
香港飞翼模型国际有限公司

地址: 广东省东莞市大朗镇富民中路402-408号飞翼楼四楼
Web: <http://www.sz-freewing.com>
Email: freewing@sz-freewing.com
Tel: 86-769-82669669 Fax: 86-769-82033233

