

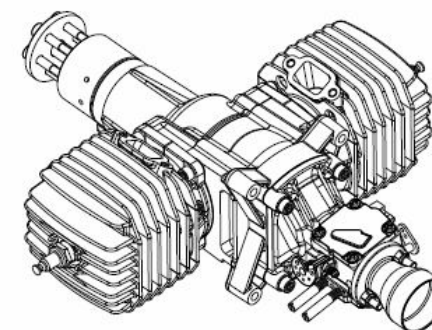

Anlage A

3W-110XiB2 R

1. Dreiseitenansicht

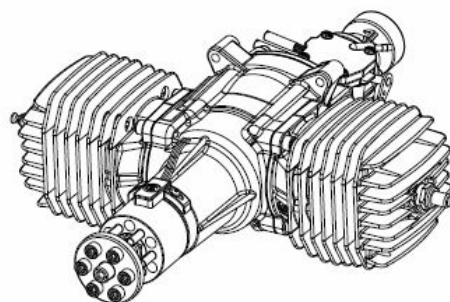
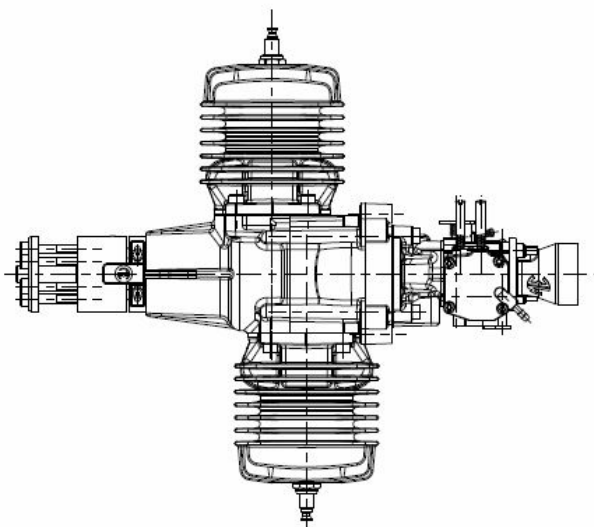
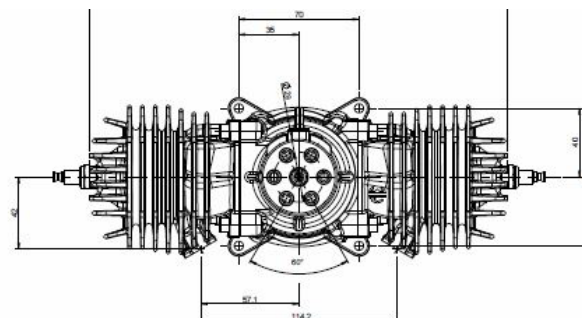
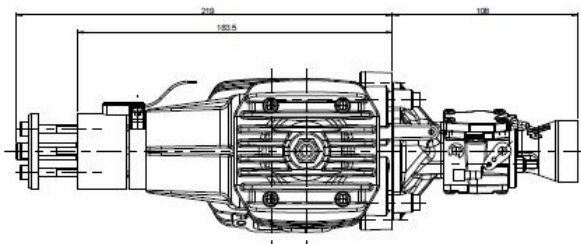

2. Bohrschablone

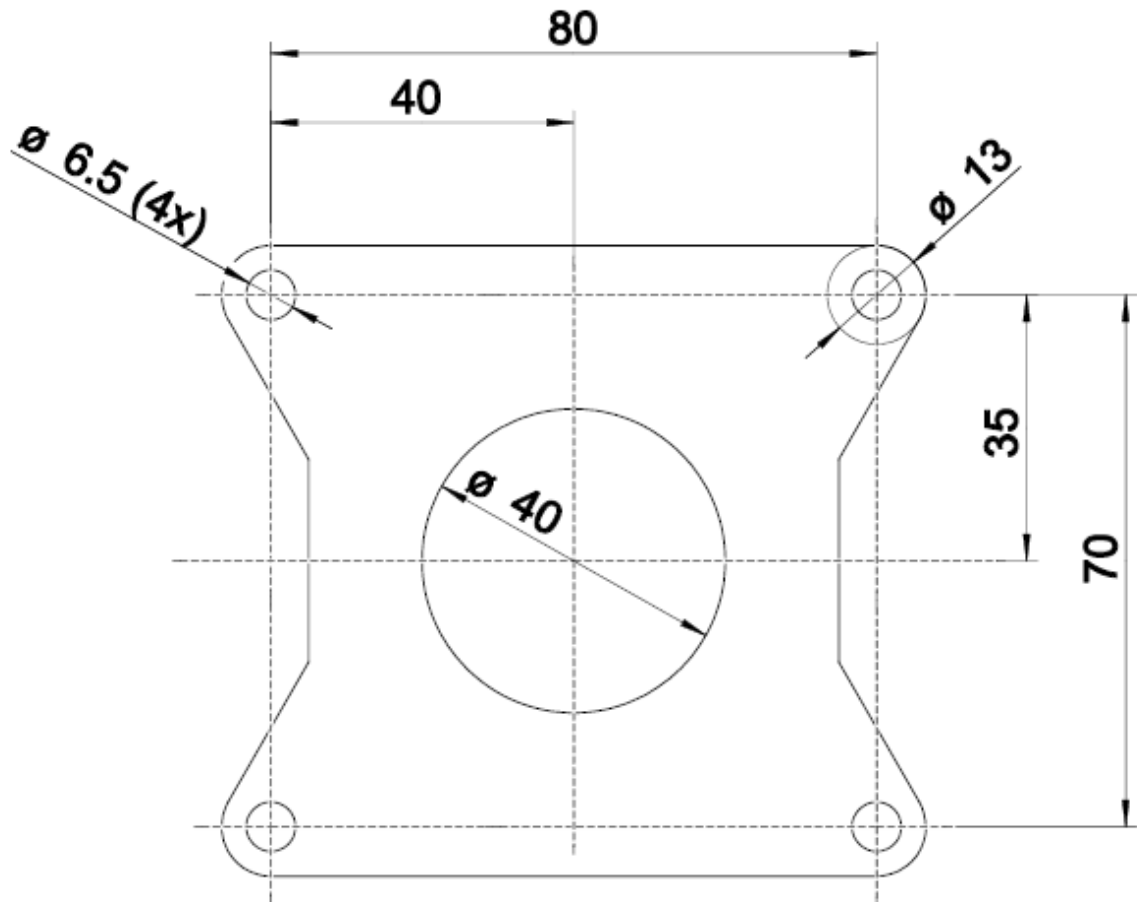



3. Technische Daten

	3W-110XiB2 R
Hubraum	110,0ccm
Leistung	11,8 PS (8,7 KW)
Bohrung	45,00 mm
Hub	35,00 mm
Drehzahlbereich	1.200 – 8.500 U / min
Gewicht inkl. Zündung	3.050 g
Kurbelwelle	3 Kugellager
Pleuel	Nadellager an beiden Enden
Benzingemisch	1 : 50 – 1: 80 (min. 92 Oktan)
IIS – Zündung	6,0 – 8,4 V, 5 Zellen oder 2 Zellen LiPo
2-Blatt Propeller	26 x 10 Holz Bestellnummer 10.101.561 26 x 12 Holz Bestellnummer 10.101.565 26 x 16 Holz Bestellnummer 10.101.569 27 x 10 Holz Bestellnummer 10.101.573 27 x 12 Holz Bestellnummer 10.101.577 28 x 10 Holz Bestellnummer 10.101.581 28 x 12 Holz Bestellnummer 10.101.585 30 x 10 Holz Bestellnummer 10.101.593
3-Blatt Propeller	27 x 14 CFK Bestellnummer 10.101.740